

WHITE PAPER



Centralised Bypass Vs Decentralised Bypass in N+1 Redundant Systems

Parallel-Redundant UPS Configurations & Bypass Systems

In a modern, interconnected world where data centres are integral to success in environments ranging from schools, hospitals, and military bases, through to supermarkets, shops, and sports stadiums, relying on raw, unprotected utility power is hugely risky, even for a short period of time.

The threat of damaging downtime and data loss is too great, so organisations deploy uninterruptible power supply (UPS) systems to protect against potential loss of – or disruption to – the electrical supply to their mission critical systems.

A UPS installation may be designed as an 'N system' where N indicates the system load requirement in kVA and kW, and the maximum power capacity of the UPS system is rated for the maximum power requirement of the load.

The main drawback of such an approach is the lack of in-built redundancy against potential system overloads, faults, or failures, and therefore an 'N system' is the least resilient enhanced power protection topology.

The preferred solution is to install multiple uninterruptible power supply units that are configured to operate together in parallel as a single overall UPS system, with an additional unit providing increased resilience to overloads or faults.

This topology is referred to as N+1 and requires two or more UPS units (with common electrical input and output connections) to communicate and operate as a single unified system.

An N+1 parallel redundant system will have at least one UPS module or unit installed in addition to those required to support the critical load.

This configuration provides additional resilience to momentary system overloads and faults, ensuring that if any one of the UPS units is off-line (e.g. manually shut down for servicing), then the critical load will continue to be fully supported by the remaining operational units in the system.



Please note the information in this document only refers to N+1 topology power protection systems.

If you are interested in learning about the bypass methods in parallel-redundant configurations, please read Riello UPS's separate whitepaper about UPS bypass in N Capacity systems.

More white papers available at www.riello-ups.co.uk/whitepapers

WHITE PAPER

Centralised Bypass Vs Decentralised Bypass in N+1 Redundant Systems

If a UPS system encounters a fault condition such as an output overload or short circuit, or an internal component failure, then the system will automatically switch to an internal static bypass mode. This will transfer the critical load from the conditioned and battery-supported UPS supply to the basic utility mains electricity via an electronic switch.

Any transfer to static bypass should be considered as a last resort in order to maintain power to the load and – other than for maintenance purposes – should only be used due to external factors such as overload, overtemperature or short circuit.

What Are The Principal UPS Bypass Methods?

There are two principal approaches to UPS static bypass arrangements – centralised or decentralised (also known as 'distributed').

Both solutions aim to fulfil the same basic end goal, i.e. to provide power continuity if the UPS system is unable to support the load. The main differences can be summarised by the physical location of the static bypass module(s) within the overall UPS system, and the electrical rating of the electronic switching components.

- **Centralised UPS Bypass**

This approach has a single common static bypass switch located in a separate cabinet, that is rated for the required capacity of the UPS system in an N or N+1 configuration as required.

This common static switch module will communicate with the UPS (rectifier/inverter) modules within the system and will be controlled by a 'Master' UPS module to ensure a managed system transfer from UPS to static bypass operation.

- **Decentralised UPS Bypass**

This configuration requires each UPS in the system to have its own separate internal static bypass switch, rated according to the maximum capacity of the individual UPS unit.

Each UPS unit in the system will separately monitor its own output, and if it becomes necessary for the UPS system to transfer to static bypass operation, then the static switch in each UPS will be simultaneously switched on and share the load in parallel.

For example: in an N+1 centralised system with three 200kVA UPS units there will be a single static bypass module rated at 400kVA; while in an N+1 decentralised system comprising three 200kVA UPS units there will be three separate 200kVA static bypass switches operating in parallel.

This basic difference in static bypass topology is applicable no matter how many UPS units are connected to make up the overall power protection system. It should also be noted that the above principles of centralised or decentralised static bypass arrangements apply to all UPS system architectures including parallel, standalone, and the increasingly popular modular systems.

Centralised and decentralised systems are both perfectly viable solutions for ensuring that a seamless system transfer to mains operation is available as and when necessary.

It is only natural that some consultants or IT managers will have their own personal preference. But in general, the choice between both approaches boils down to a few key factors and should be decided on a case-by-case basis.

Factors Impacting UPS Bypass Choice

Reliability

Depending on the application, organisation, or supplier, the overall reliability of a critical power protection installation may be assessed by one of several criteria.

For instance, there's the most common and self-explanatory metric, Mean Time Between Failures (MTBF), there's Mean Down Time (MDT), and there's Mean Time To Repair (MTTR), which ideally should take into account travel time and spares provision.

WHITE PAPER

Centralised Bypass Vs Decentralised Bypass in N+1 Redundant Systems

While these metrics all have some merit, they are derived from statistical data and therefore need to be treated with caution.

For example, a specified MTTR of two hours may be wholly accurate, but only if a suitably qualified UPS engineer is on site with the parts and equipment necessary to complete the repair. This metric does not account for engineer or parts availability and lead time, or the initial engineer travel time to site.

There are two main areas of resilience for consideration:

- Operational resilience

In theory, both bypass systems are as reliable as each other, although it can be argued that because a decentralised approach requires more components, technically that could make it slightly less reliable.

The centralised method, however, introduces an unappealing single point of failure (SPOF) into the static bypass supply.

Although a second bypass module could be introduced to operate in parallel to eliminate any SPOF within the static bypass supply, this in essence would be the same as mirroring the decentralised approach and would also be extremely expensive to implement.

A consideration with older decentralised UPS installations was how the multiple bypass switches within the system operated together under fault conditions, and whether they performed a simultaneous transfer to bypass.

These concerns were mainly due to the time delays associated with bypass switching in older UPS systems. Within a modern UPS the bypass switching transfer time is invariably instantaneous.

In a planned (or normal) transfer – when the user commands the system to switch to static bypass – the UPS receiving the command will transmit the request to all other units in the system via the parallel CANBUS communication line.

All units in the parallel system will then simultaneously transfer to static bypass operation.

During an emergency scenario such as an output short circuit, the system inverters will become incapable of maintaining the output voltage.

Each UPS unit will independently detect the output fault/overload, and a simultaneous transfer to static bypass will be initiated.

- Maintenance resilience

During routine maintenance in a system designed for N+1 operation, a decentralised system can remain fully operational, and will provide static bypass provision at all times.

A centralised system designed for N+1 operation can also be maintained without compromising the system resilience. But when the centralised bypass cabinet is maintained, the static bypass functionality of the system will be unavailable.

Fundamentally, a decentralised bypass structure delivers N+1 redundancy for both the UPS and the bypass. Whereas the centralised method provides N+1 for the UPS, but only N redundancy for the static bypass switch.

There is another question to consider when evaluating maintenance reliability – what happens if the static bypass itself fails?

If there's a fault within the static bypass module in a centralised system, then the static bypass functionality of the system is unavailable.

In a decentralised design, if one of the separate static bypass switches fails, then the remaining static switches are still capable of supporting the load, if required.

WHITE PAPER

Centralised Bypass Vs Decentralised Bypass in N+1 Redundant Systems

Power balancing

One of the biggest advantages of a centralised bypass system is that it eliminates any potential issues introduced due to different cable lengths – and hence impedances – between the input and output cabling of each UPS module in the parallel system.

Having a single current through the centralised static bypass line prevents any power balancing inconsistencies when the system is operating in static bypass mode.

When a decentralised UPS system is transferred to static bypass, the internal electronics (rectifier/inverter) within each UPS unit in the system will be switched off and effectively circumvented by connecting the input supply to each UPS unit through to the output via the internal static bypass switches.

Therefore, the length and total impedance of the cabling fitted between the UPS input and output will determine how much current flows through the static bypass switch in each unit.

In order to ensure accurate load sharing during static bypass mode, the total length of cabling connecting

each UPS to the common input and output points needs to be the same.

Differences in total cable lengths – and therefore impedances – can cause the current flow to become unbalanced through the individual UPS static bypass switches. Such an unbalanced current flow could potentially lead to a static switch overload or nuisance tripping of a UPS unit's external input or output protective devices.

It may be difficult to ensure 100% perfect power balancing by exactly matching the total length of the input and output bypass cabling through each UPS unit, particularly with systems that have long cable runs.

However, satisfactory power balancing should be achievable providing the maximum difference in the total cable length through each UPS unit doesn't exceed around 10%.

One option to overcome the issue of power balancing within a decentralised bypass – assuming that the cable lengths cannot be adjusted – would be to fit line reactors on the input to each UPS unit, but this would add significant additional costs to the system.

*A typical N+1 Redundant UPS System with Centralised Bypass
Where each UPS is rated at 200kVA with the Centralised Bypass rated at 400kVA*

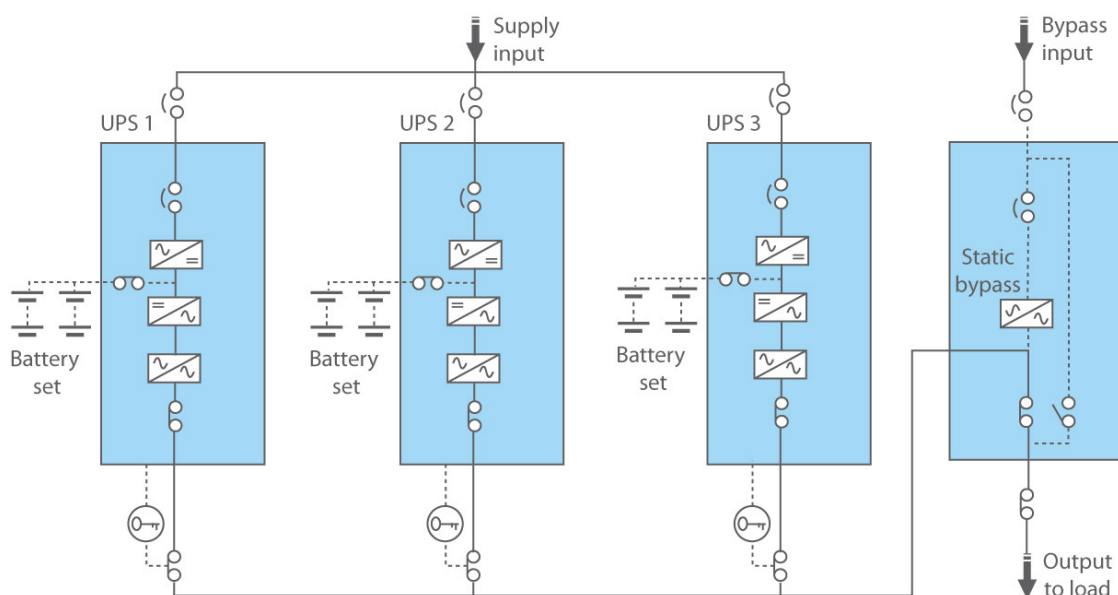

WHITE PAPER

Centralised Bypass Vs Decentralised Bypass in N+1 Redundant Systems

Cost

Financial constraints are obviously important to consider, both in terms of the initial capital expenditure to install the UPS system, as well as the ongoing running and maintenance costs.

As a rule of thumb, a centralised bypass system is slightly more expensive than a decentralised one.

This is due to the need for the separate dedicated cabinet containing the static bypass switch, plus all the necessary additional components, cabling, and controlling infrastructure.

The cost difference is greatest with a smaller parallel-redundant UPS system. However, as the total capacity of the system design increases, economies of scale become a factor and the disparity in cost between both approaches tends to decrease.

This explains why centralised bypass systems tend to be more common for large-scale installations.

There is another cost factor to consider, namely the system switchgear requirements. In a single input decentralised system, there will be a separate single input and output breaker for each of the UPS units in the system – note that the input breaker will feed both the rectifier and internal bypass line for each UPS unit.

Therefore, the required number of separate input and output switches/breakers would match the number of UPS units in the installation.

In comparison, a centralised system would require the same quantity of input and output switches/breakers for the UPS units, but additional input/output switchgear would also be required for the separate static bypass cabinet, resulting in higher initial installation costs.

On a similar theme, a centralised system is effectively a dual input system, where the UPS rectifier modules are fed from one source, and the bypass module is fed from a separate source and/or a separate breaker.

To replicate this dual input functionality in a decentralised system, you would need to double the number of breakers supplying each UPS unit.

Therefore, the system design architecture will directly influence the required quantity of external UPS switchgear, which is an additional cost that must be considered.



Rectifier

A rectifier is one of the key components in an online (double-conversion) UPS system. Its primary role is to convert the input power supply from alternating current (AC) to direct current (DC). The rectifier's other function is to charge the batteries so they remain at the correct float voltage.

Footprint & Future Planning

The most obvious point to make here is that a centralised system will require the additional space to house the standalone static bypass cabinet.

In terms of capacity, the decentralised method does provide greater flexibility and the potential for future growth of the system. If the UPS system requires increased capacity, then additional units can simply be added into the parallel system on a 'pay as you grow' basis.

Note that depending upon the UPS type and rating, there will be a limitation on the number of separate UPS units that can be connected in parallel.

A centralised bypass is naturally more restrictive with regards to future system expansion, so careful consideration must be taken during the initial system design.

If the bypass module installed at day one isn't rated to deal with the load applied at day two, it will need replacing with a larger module.

Alternatively, there is the danger of initially installing a bypass which is too large and oversized for the needs of the system, which in turn results in additional and unnecessary upfront expense.

WHITE PAPER

Centralised Bypass Vs Decentralised Bypass in N+1 Redundant Systems

Summary

There isn't a definitive answer as to whether a centralised or decentralised bypass system is the best solution for every situation. It's a decision that should be made on a case-by-case basis.

IT and facilities managers need to weigh up a range of issues, principally their financial and space constraints, their present and future capacity needs, and the impact each of the design architectures could have on overall system reliability and resilience.

Broadly speaking, the main advantages of a decentralised bypass system – greater scalability and lower initial capital investment – make it a more suitable option for smaller or medium-sized installations utilising UPS power modules up to 200kVA.

While the reliability and performance at scale provided by centralised bypass systems means they are more likely to be selected for installations in larger datacentres and facilities, particularly those with multiple UPS units of 250kVA and above.

Centralised Bypass Systems

Advantages

- Easier to balance power during bypass mode
- Fewer mechanical components and switching devices
- Easier installation and deployment with relatively simple switchgear
- Scalability for larger facilities with defined growth plans
- Suitable for larger data centres running multiple power modules of 250kVA and above

Disadvantages

- Single Point of Failure (SPOF) as the system is dependent on a single static switch and bypass breaker
- Loss of bypass functionality during routine maintenance of the static bypass module
- Higher initial capital costs and larger footprint due to additional bypass cabinet
- Increased risk of oversizing during initial installation
- Slightly higher ongoing maintenance and service costs

Decentralised (Distributed) Bypass Systems

Advantages

- Lower upfront cost and smaller footprint as no dedicated bypass cabinet is required
- Not dependent on a single static switch or bypass breaker
- Bypass functionality continues during routine maintenance
- Scalability for facilities with future growth plans; potential to grow incrementally without the risk of oversizing at installation
- Suitable for small to medium-sized spaces utilising UPS power modules up to 200kVA

Disadvantages

- Importance of balancing the power during static bypass mode, due to far less tolerance for differences in the cable impedance between units
- Additional switchgear costs for dual input systems